



DISCOVERY EVO

The master of versatility

FAGERHULT

There is a Discovery Evo for every occasion. What's yours?

When we launched Discovery the premise was entirely new. A straightforward, simple and easy to work with concept where a single luminaire would satisfy the need for good energy efficient lighting in environments that were previously too tricky to solve. Today, Discovery is in stairwells, corridors, kitchens, and bathrooms in both public and private environments, including aged care. In ceilings and on walls. Indoors and outdoors.

Now we are taking Discovery to the next step of its development; reinforcing all the benefits of the concept and with additional features based on LED technology. Discovery Evo is even more versatile, with new applications for even more demanding environments. Discovery Evo has tough-to-beat lighting performance with extreme energy efficiency and a comfortable, space-creating light pattern. Discovery Evo is more refined in its form and more solid in its expression. Discovery Evo is even quicker to install. A completely new luminaire – endless possibilities.





Supremely versatile

Discovery Evo fulfils the lighting needs under all circumstances. The basic model, in a classic white design, is IP44 classified, available for ceiling and wall as well as recessed mounting. Discovery Evo is also available in an IK10 anti-ligature design as well as in a IK10/IP55 model for outdoor use – in black, anthracite grey and white finishes.









Superior lighting performance

With an efficiency of 118 lm/W and luminous flux of 2500 lm, Discovery Evo sets a new standard in its luminaire class as a functional and cost efficient solution in any area of a building.

Quickest installation?

A large number of luminaires installed in often difficult-to-work spaces require efficient installation. Discover Evo is one of the quickest on the market. An innovative installation solution with body and recess kit provides a user friendly light package. The LED module and diffuser are placed together which makes the installation smooth and safe as the lighting element can be put to one side while the body is being installed.



1 Recess ring and luminaire consisting of LED module, diffuser and body.



4 Draw the cabling into the luminaire and release the three locking springs. Install the luminaire in the hole.



2 Separate the light unit and body.



5 Attach the safety wire and connect the snap-in connector. Install the light unit in the body using a bayonet fitting.



3 Place the luminaire body in the recess module and lock it with a click.



6 The installation is complete. Switch on the luminaire.



Light control

Discovery Evo can be equipped with presence control based on microwave sensors or PIR. The microwave sensors offer an on and off function or absence dimming high/low/off and it's now possible to control the absence dimming function via DALI in situations where you want to combine one master luminaire with several slave luminaires. A functional solution in laundry rooms, storerooms or changing rooms for example.

The solution can also be optimised with e-Sense Move; a control system specially designed for stairwells, corridors and other communication areas. Programming takes place easily by remote control.

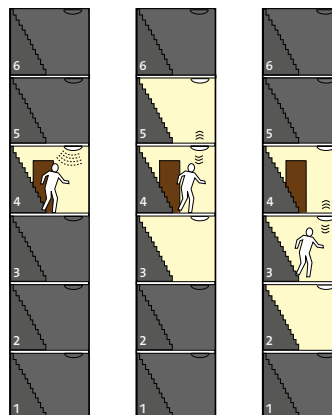

This is how e-Sense Move works:

1. Presence is detected on 4th floor, light turns on.

2. Simultaneously the sensor transmits RF-commands to the closest floors to turn lights on.

3. If a person then moves downwards, the sensors will continue to turn the light on ahead of person being detected.



Discovery Evo



Installation

Four securing holes. For recess or surface mounting on ceilings or walls. Brackets for recessed installation ordered separately, please see accessories. There are holes for a surface mounted installation socket.

Connection

230 V integrated LED driver. Snap-in terminal block 5 × 2.5 mm². 1-phase through-wiring possible. Cable entry at rear or via knockouts for surface mounting, through wiring 0° or 180°.

Design

Luminaire body of polycarbonate and diffuser of opal polycarbonate.

Emergency lighting

The product is equipped with the ability to connect a monitoring system based on communication via DALI. The system is not dependent on a DALI system being connected or in operation. Emergency lighting luminaires can be supplemented with sensor on request.

Accessories

Anti-ligature casing in white enamelled sheet steel. Supplied with safety screws (tamper-proof torx) IK10, IP 55. Outdoor casing in lacquered aluminium, IK10, IP 55. Surface mounted mains cable possible.

LED-information

Driver life time: up to 100.000 h/10 % (max failure).

Luminaire								
System, W	K	lm	lm/W	Ra (CRI)	Life	SDCM	kg	
19	3000	2438	128	≥ 80	L ₉₀ B ₅₀ 60.000 h	3	1.6	FG-57728-0 ●
19	4000	2566	135	≥ 80	L ₉₀ B ₅₀ 60.000 h	3	1.6	FG-57729-0 ●
Emergency lighting luminaire, decentralised 3 h, self-test AT4 + DALI surveillance, can be supplemented with sensor.								
19	3000	2438	128	≥ 80	L ₉₀ B ₅₀ 60.000 h	3	2.0	FG-57728-800
19	4000	2566	135	≥ 80	L ₉₀ B ₅₀ 60.000 h	3	2.0	FG-57729-800

All versions listed above are stocked in Australia.

For current information, please refer to our website.

All photometric, spectrometric and electrical data have a tolerance of ±10%.

Accessories

Recess rings including spring clips for recess mounting	92650
Anti-ligature casing IK10, white	92651
Mounting plate for recessed installation in soft tile suspended ceilings.	92652
Outdoor casing IK10, white (RAL 9010)	92653
Outdoor casing IK10, anthracite grey (Gris 900 Sablé str.)	92654
Outdoor casing IK10, black (RAL 9005 str.)	92655
Remote control e-Sense Move DALI	86305

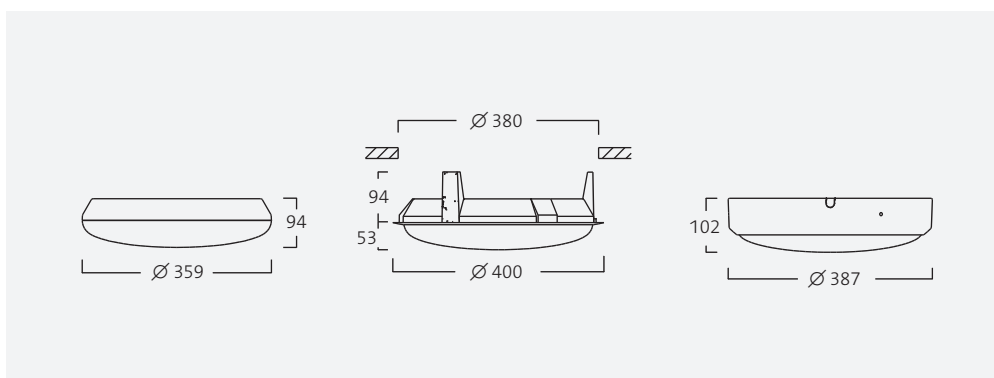

Outdoor accessories.



eaglelightingaustralia

www.eaglelighting.com.au
eagle@eaglelighting.com.au

VICTORIA

17-19 Jets Court
Melbourne Airport VIC 3045
P 03 9344 7444
F 03 9344 7433

NEW SOUTH WALES

Unit 4, 21 Mars Road
Lane Cove NSW 2066
P 02 9420 5799
F 02 9420 5988

QUEENSLAND

53 Caswell Street
East Brisbane QLD 4169
P 07 3891 0744
F 07 3891 0755

AUSTRALIAN CAPITAL TERRITORY

M 0411 889 406

DISTRIBUTORS - AUSTRALIA

WESTERN AUSTRALIA

H.I. Lighting Pty Ltd
111 Broadway
Bassendean WA 6054
P 08 9377 1322
F 08 9377 1761

SOUTH AUSTRALIA

H.I. Lighting SA Pty Ltd
8 Hender Avenue
Magill SA 5072
P 08 8304 8500

TASMANIA

Southern Lighting & Distribution
34 Federal Street
North Hobart TAS 7000
P 03 6231 5599
F 03 6231 5211

DISTRIBUTORS - NEW ZEALAND

AUCKLAND

Fagerhult New Zealand
Level 1, 18A Neilpark Drive
East Tamaki, Auckland 2013
M +64 21 655 609
M +64 21 509 248

WELLINGTON

Fagerhult New Zealand
M +64 21 597 900

SOUTH ISLAND

Fagerhult New Zealand
M +64 21 193 4430