

27/8/21

### **Eagle Lighting take-back and recycling**

As an Australian manufacturer committed to sustainability, Eagle Lighting has integrated Circular Economy principles into all aspects of our business. As part of our operating procedures, we have created the Eagle Lighting Takeback and Recycle Program. This gives our customers the confidence that Eagle Lighting “end of life” products will be managed responsibly and clearly demonstrates how we live up to our brand promise of ‘Better lighting for people and planet’.

Eagle Lighting have partnered with several recycling companies throughout Australia and New Zealand to ensure we deliver the most environmentally responsible solution.

The recycling program will assess and break down the products into the following material groups:

Plastics

Glass

Ferrous

Printed Circuit Boards (PCBs)

Batteries

Gold

To discuss the take back program further please contact your Eagle Lighting representative.

Peter Prodromos



Head of Operations

---

**Victoria (Head Office)**

17-19 Jets Court,  
Melbourne Airport 3045  
+61 3 9344 7444

**New South Wales**

Level 1  
71-73 Alexander Street.  
Crows Nest 2065  
+61 2 9420 5799

**Queensland**







53 Caswell Street.  
East Brisbane 4169  
+61 7 3891 0744

**Australian Capital Territory**

+61 411 889 406

# Educo Suspended

## Installation Instructions

	Luminaire's light distribution is direct.
<b>LED</b>	Denotes which light source/light sources that can be supplied with the luminaire.
<b>IP44</b> 	IP Classification: Product is IP44 : Protected against solid objects over 1mm (tools, wires, and small wires). Protection against splashing water from any direction (splash proof) - limited ingress permitted.
	Class 1: Appliances with functioning insulation. Equipped with an earth termination.
	<b>RISK OF FIRE:</b> (a) The minimum clearance distance from the top of the luminaire to any normally flammable building element is 100mm. (b) The minimum clearance distance from the top of the luminaire to any building insulation is 100mm. (c) The minimum clearance distance from the side of the luminaire to any normally flammable building element is 100mm. (d) The minimum clearance distance from the side of the luminaire to any building insulation is 100mm. <b>WARNING – RISK OF OVERHEATING OR FIRE IF THE CLEARANCE DISTANCES ARE COMPROMISED.</b>
	Luminaire is available in designs for conventional emergency lighting operation.
	RCM: Indicates a device's compliance with applicable ACMA technical standards.
	ESD: Personnel should be grounded when unpacking or handling the luminaire.

## Important Information

Please read this guide carefully before installing or maintaining this equipment. Data should be used as an INDICATION only and good electrical practices should be followed at all times.

Must only be installed by a licensed electrician.

If the external flexible cable or cord of this luminaire is damaged, it shall be exclusively replaced by the manufacturer or their service agent or a similar qualified person in order to avoid a hazard.

For indoor use only.

A qualified electrician, in accordance with AS/NZS 3000:2007 wiring regulations should carry out connection to mains wiring.

This unit must be EARTHED.

Ensure that the rated voltage and frequency requirements are compatible with the available mains supply, 220-240V 50Hz.

Cleaning of reflectors and lenses should be carried out using clean, soft and lint free cloths and anti-static cleaning fluid.

Do not carry out high voltage insulation test i.e. 500/1000V this may damage the fixtures electrical components.

This installation instruction is relevant to the standard version of the above family. Customised variants may have mechanical changes or may have changed mounting procedures.

# Educo Suspended

## Installation Instructions

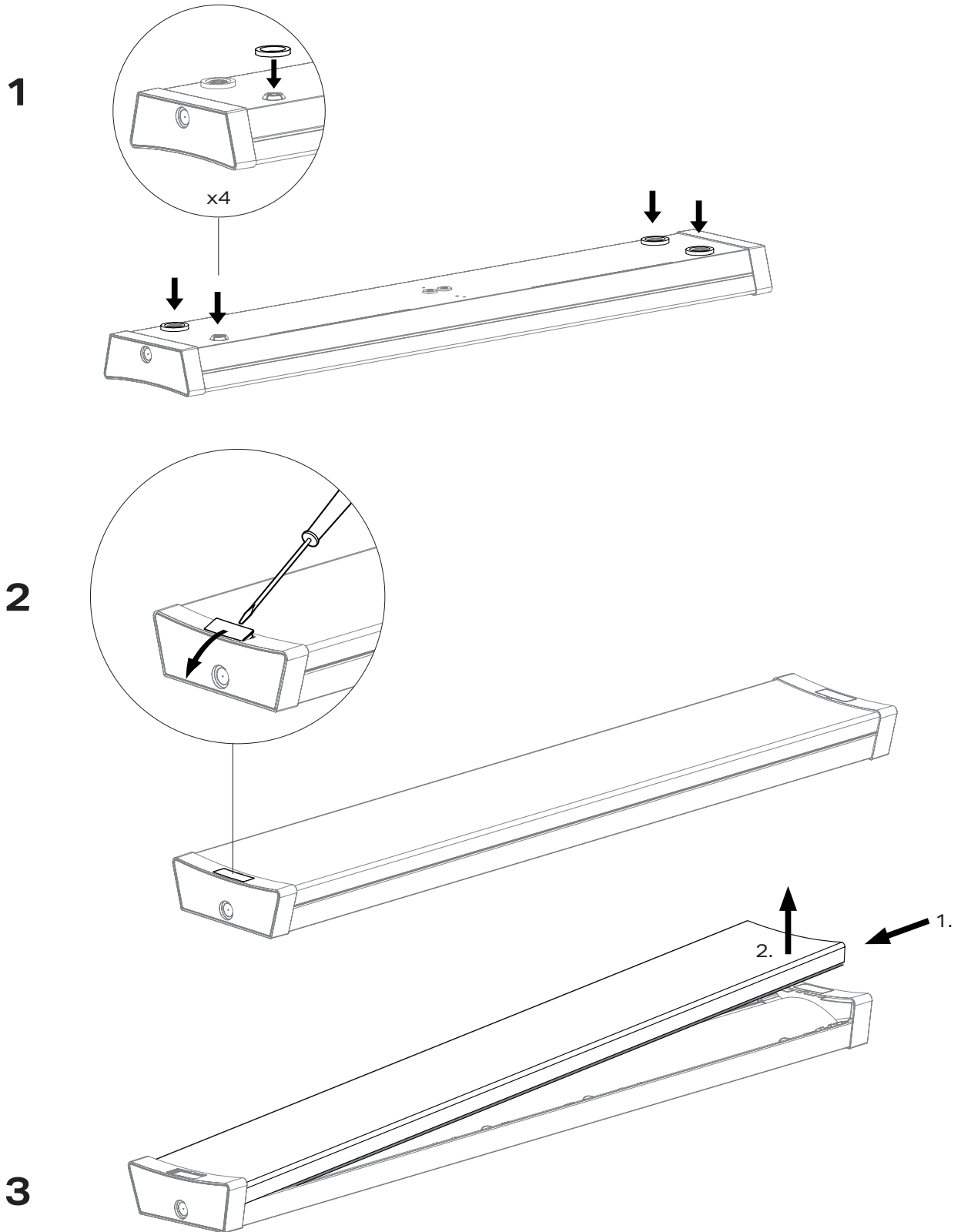

This installation instruction is relevant to the standard version of the above family. Customised variants may have mechanical changes or may have changed mounting procedures.

# Educo Suspended

## Installation Instructions

4

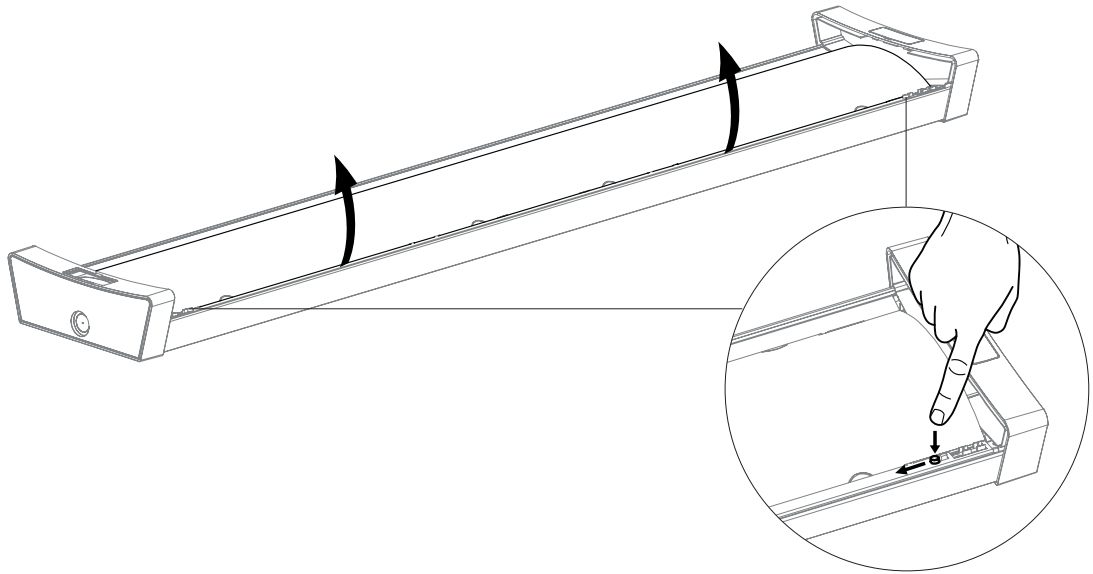

5

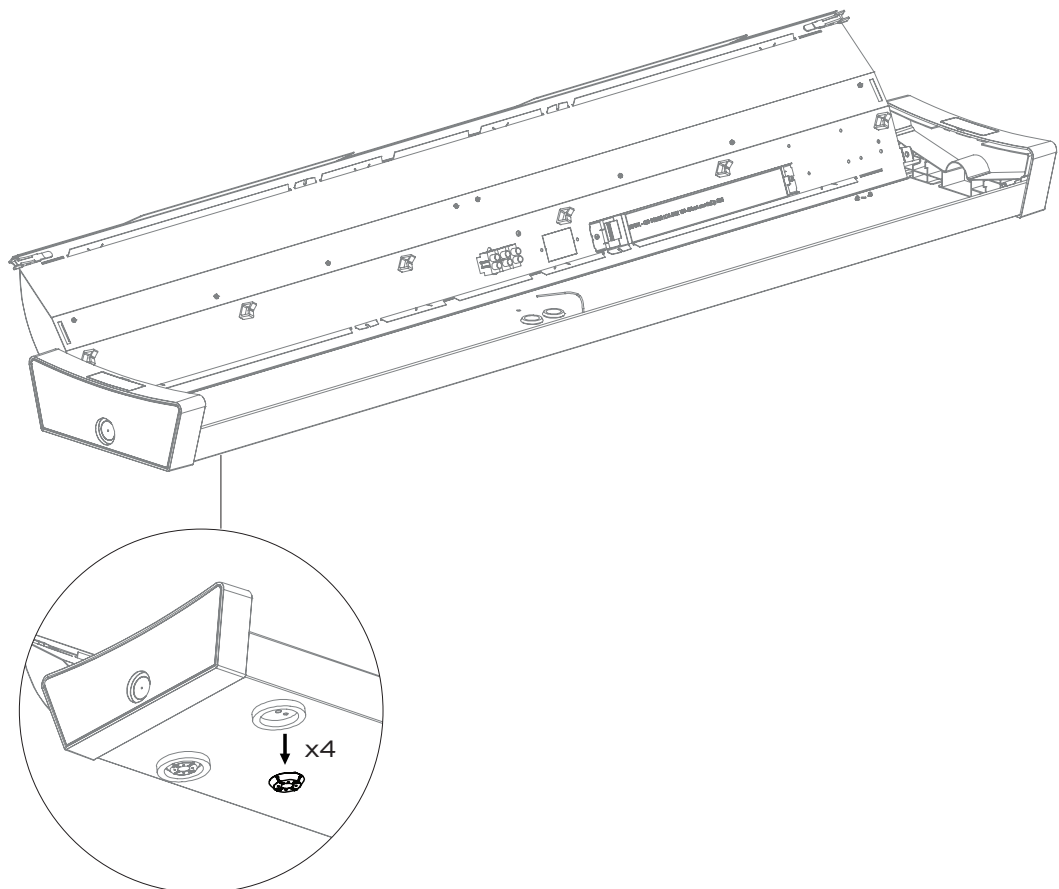

This installation instruction is relevant to the standard version of the above family. Customised variants may have mechanical changes or may have changed mounting procedures.

# Educo Suspended

## Installation Instructions

6

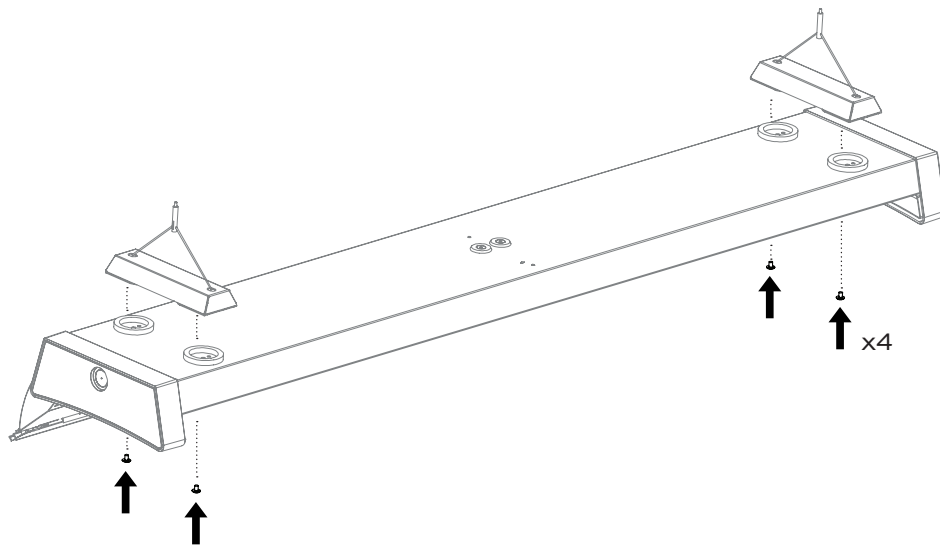

7

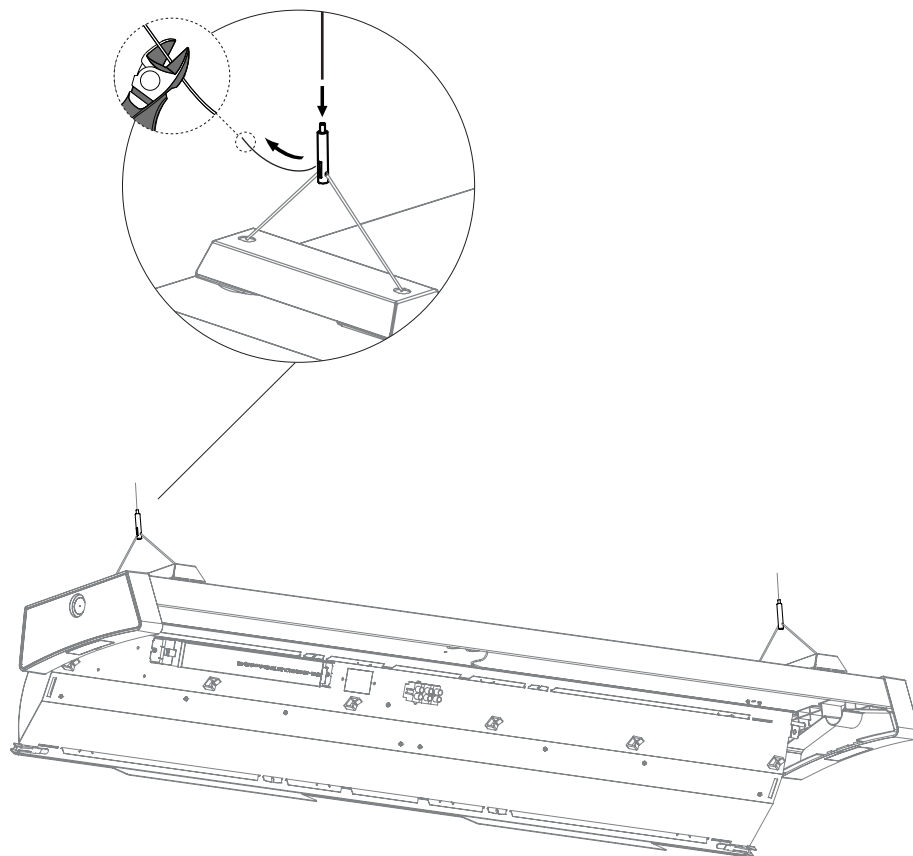

This installation instruction is relevant to the standard version of the above family. Customised variants may have mechanical changes or may have changed mounting procedures.

# Educo Suspended

## Installation Instructions

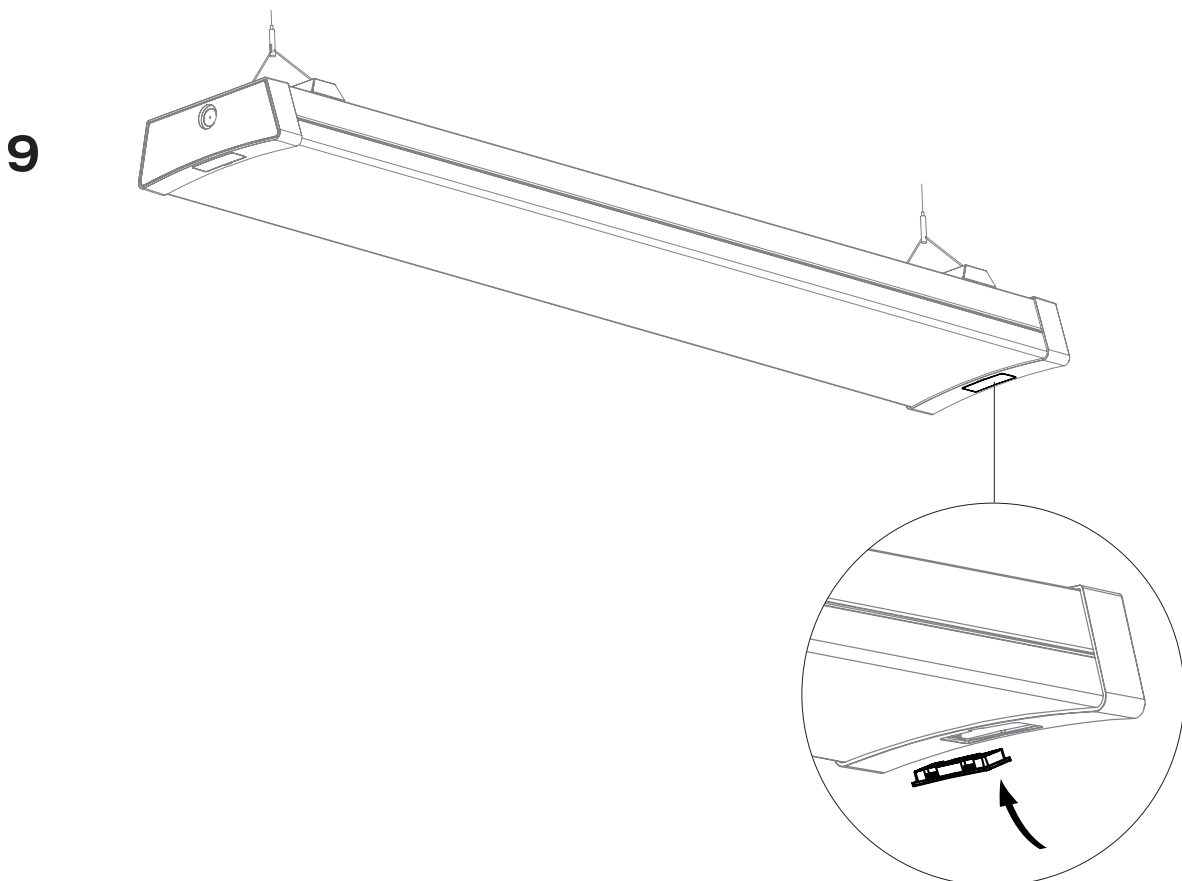
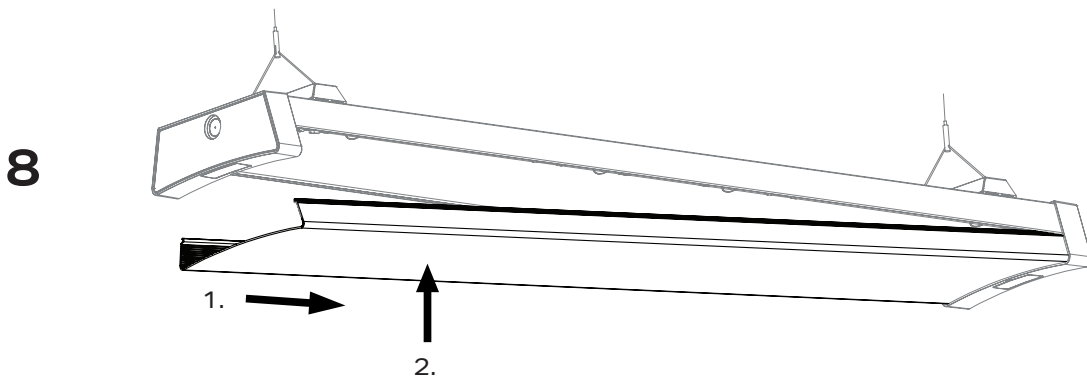

This installation instruction is relevant to the standard version of the above family. Customised variants may have mechanical changes or may have changed mounting procedures.