

# ELLE Recessed

## Installation Instructions

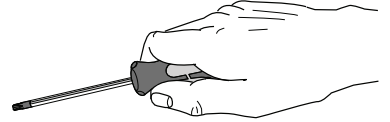

For use in ventilated or unventilated spaces

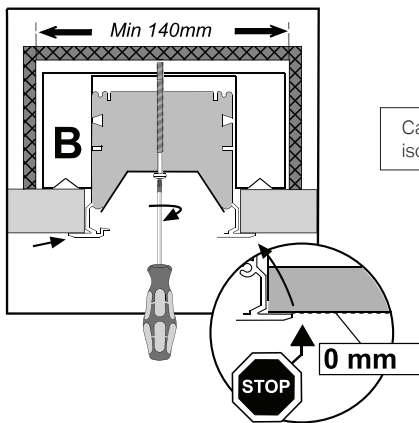
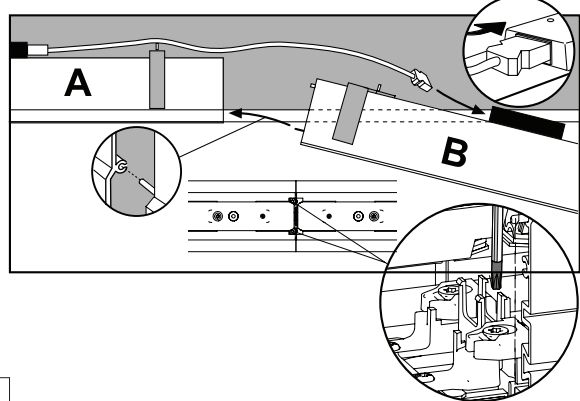
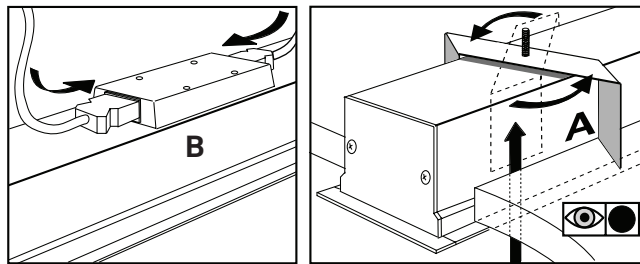
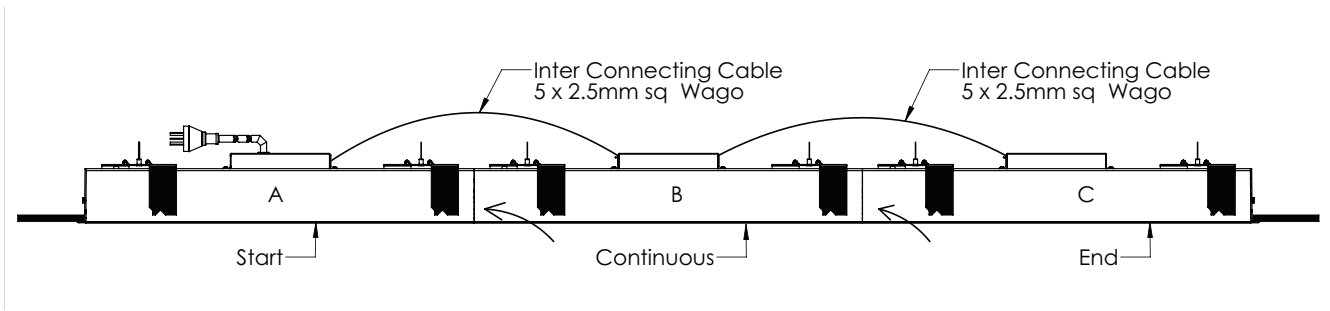
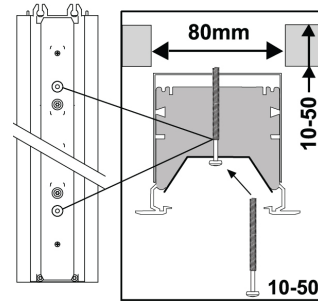
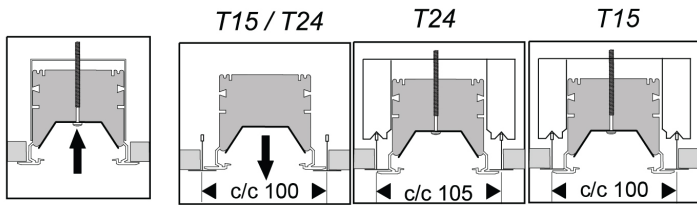

Can be covered with isolating material

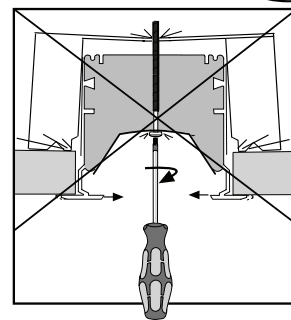

Do not over tighten

# ELLE Recessed

BETA

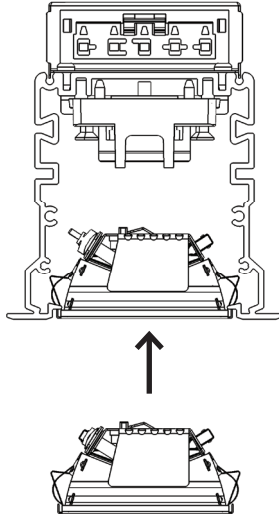

OPAL

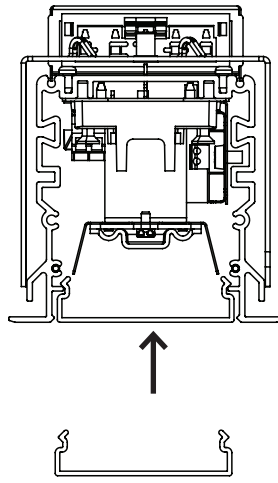

DELTA / ASYMMETRIC

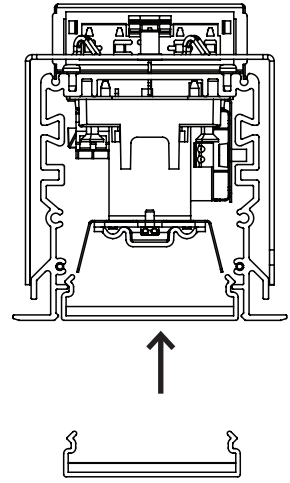

BETA

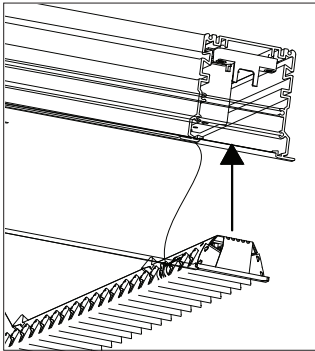

OPAL / DELTA / ASYMMETRIC

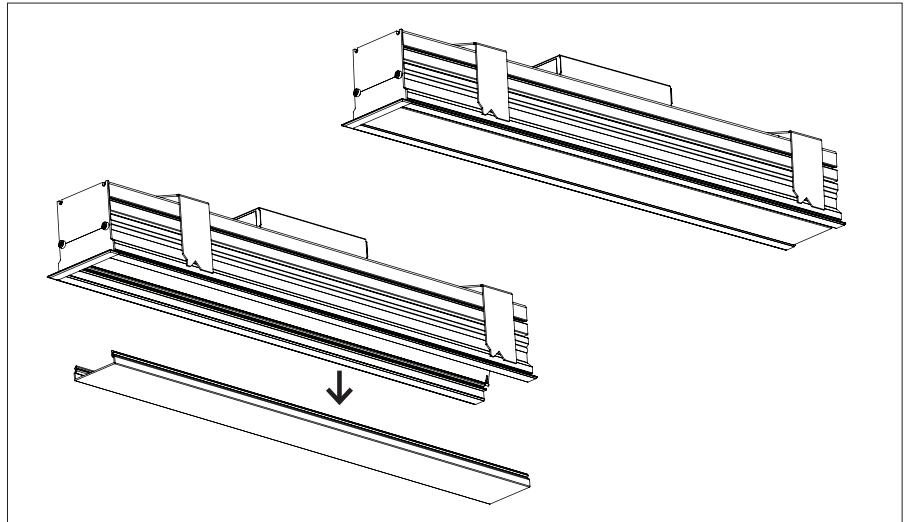

# ELLE Recessed

OPAL / DELTA / ASYMMETRIC

BETA

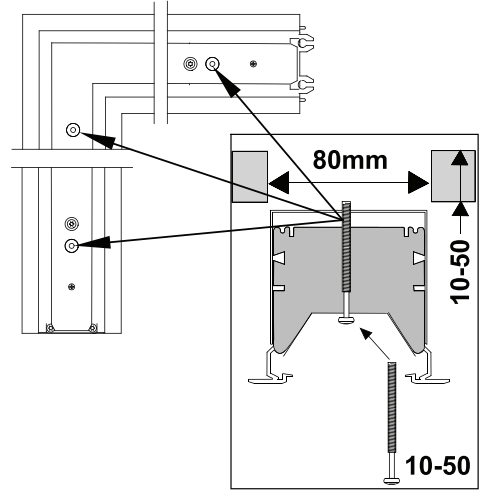
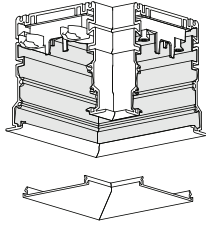
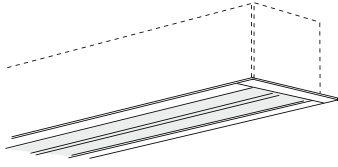

For use in ventilated or unventilated spaces

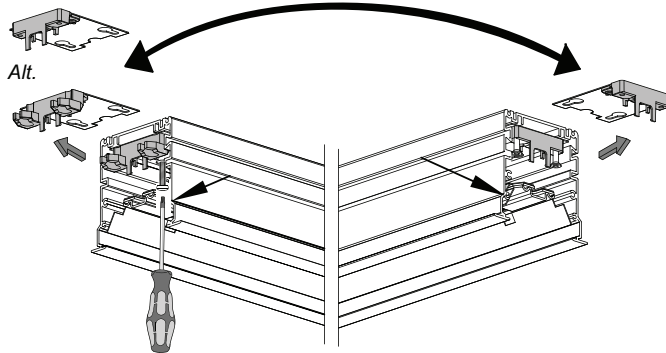
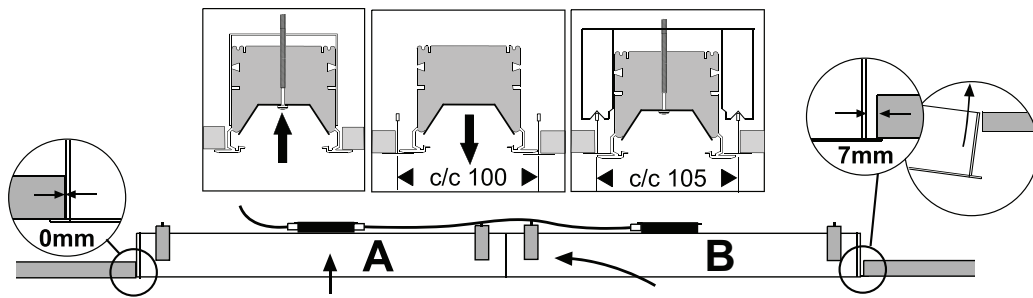

# ELLE Recessed

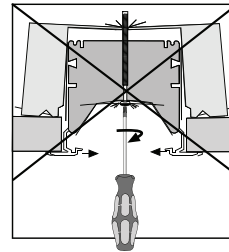
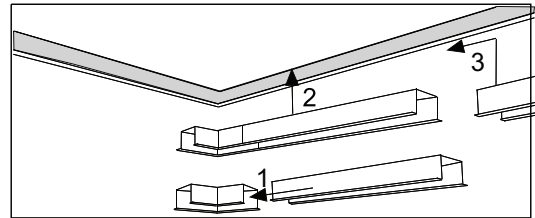
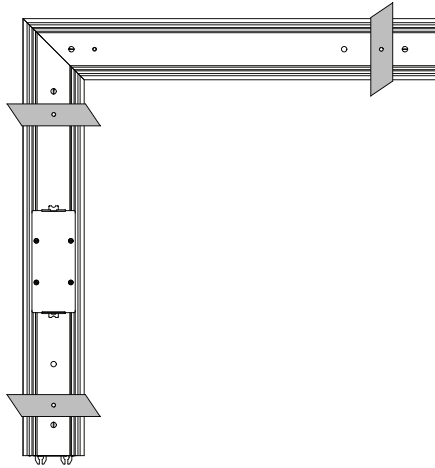
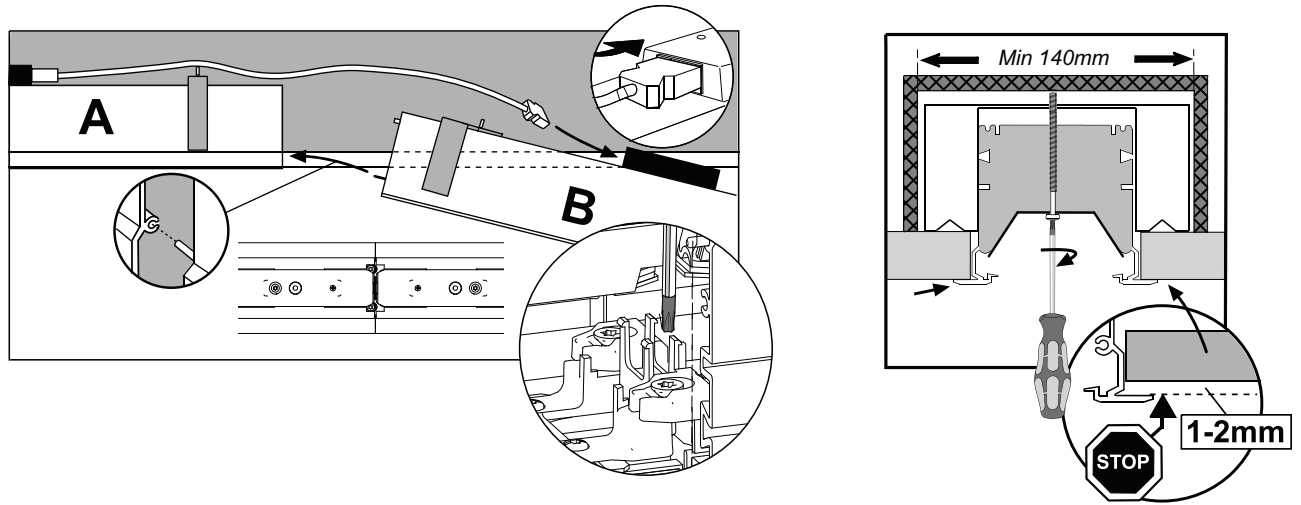

Do not over tighten

BETA

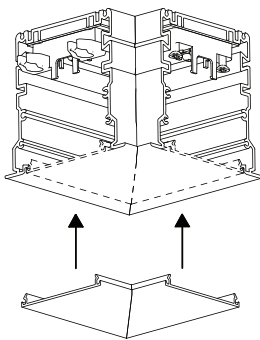

BETA

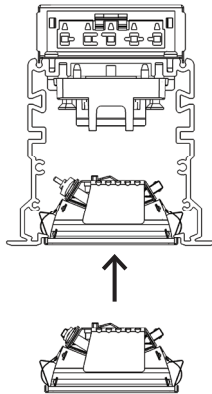

OPAL

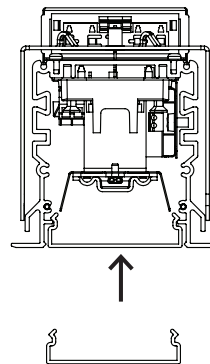

DELTA/ASYMMETRIC

